



---

## ***QNAP and Failover Technologies***

---



**USE MC/S WITH QNAP NAS**

## How to connect an iSCSI initiator on Windows 2008 with MC/S feature

QNAP provides you what others cannot!

MC/S (Multiple Connections per Session) enables you to have multiple TCP connections per session to reach an iSCSI target. This ensures better performance, and provides load balancing and failover.

MC/S is part of all x86-based QNAP NAS, e.g. TS-239, TS-439, TS-509, TS-639, TS-809 (see [http://www.qnap.com/images/products/comparison/Comparison\\_NAS.html](http://www.qnap.com/images/products/comparison/Comparison_NAS.html))

In this application note, we will connect an iSCSI target with multiple connections.



Benefits of using MC/S with a QNAP NAS:

- It allows **better performance!** Using several TCP connections for data transmission will enhance network throughput.
- It allows **Failover!** In case of network problem (e.g. faulty cable, switch power unit malfunction), it will avoid downtime! All applications will remain online!
- It allows **load balancing!** Whenever a large transfer occurs, it can use different switches for the transfer to avoid a possible switch overload if only one is used!

Before getting started, please know:

- DO NOT use NIC Teaming on the server: NIC Teaming used with iSCSI is not supported by Microsoft.
- DO NOT use MC/S and MPIO together to connect to a target. Microsoft does not support that configuration: *"Although it is technically possible to layer Microsoft MPIO and MC/S together since they function at different layers in the Windows stack, Microsoft does not support the layering of MPIO and MC/S due to complexities this can introduce if troubleshooting is needed on a configuration."*
- (See "Microsoft iSCSI Software Initiator Version 2.X Users Guide"  
<http://download.microsoft.com/download/A/E/9/AE91DEA1-66D9-417C-ADE4-92D824B871AF/uGuide.doc> )

In this Application note, you will find:

<i>Some Possible Physical Network architectures</i>	4
1 network link	4
2 network links	4
<i>MC/S over a single network interface</i>	5
<i>MC/S over a 2 network interfaces</i>	6
<i>Different possible failures and failover concept</i>	7
Handled by MC/S feature	7
Handled by QNAP Trunking mode (failover setting)	8
<i>Pre-requisites of using MC/S (detailed later)</i>	8
<i>Steps review</i>	8
Set up an iSCSI target on your QNAP NAS	9
Connect to your QNAP iSCSI portal	9
Connect to your iSCSI target (first connection)	12
Add the second connection	15
<i>Check the settings</i>	23
<i>Example of a failover</i>	27
<i>Advices</i>	28
On your Windows 2008 server, configure your network interface properties.	28
On your NAS administration interface	29
You can also unbind unnecessary protocols from your iSCSI NICs	30

Two different configurations will be demonstrated in this application note.

- The first one is based on a simple network architecture.
- The second one will use a more advanced configuration to allow failover and load balancing.

## Some Possible Physical Network architectures

---

### 1 network link

---

The simplest way to try MC/S is to have a simple connection with 1 physical interface on each side.

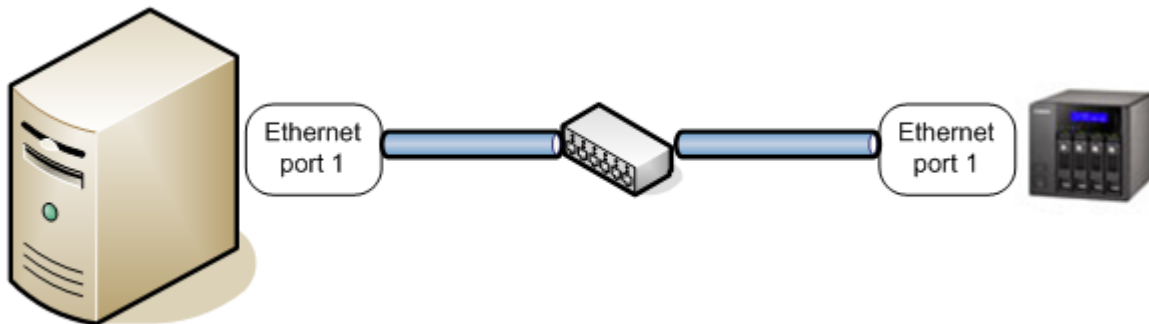

### 2 network links

---

Dual connection: 2 network interfaces on each side.

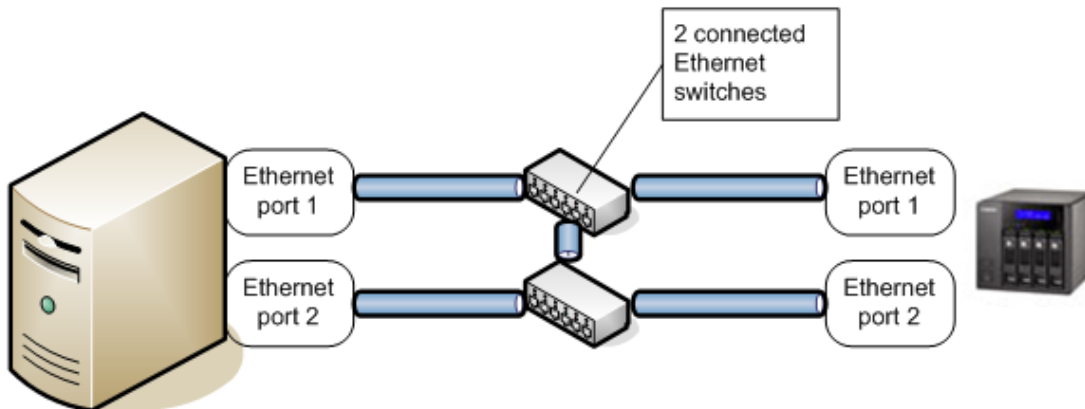

This architecture offers failover, load balancing and performance enhancement.

We will see in details how to set up the MC/S feature on this network architecture to allow failover.

## MC/S over a single network interface

---

In this example, we will have only one network connection on each side. Without MC/S, one connection to an iSCSI target would result in 1 session each time you click "logon" to logon and connect to an iSCSI target. Each session is composed in this case with 1 TCP connection. It would look like:

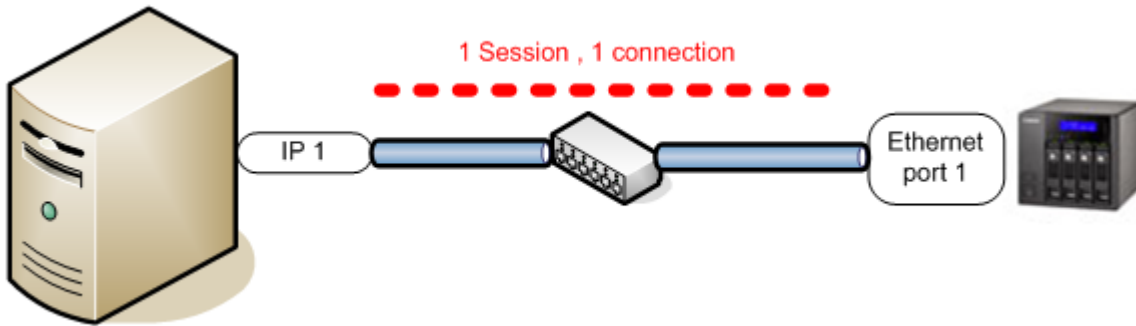

With MC/S, we can have more than 1 TCP connection for each session. That means you can logon onto the target and add several connections for the same session. It would look like:

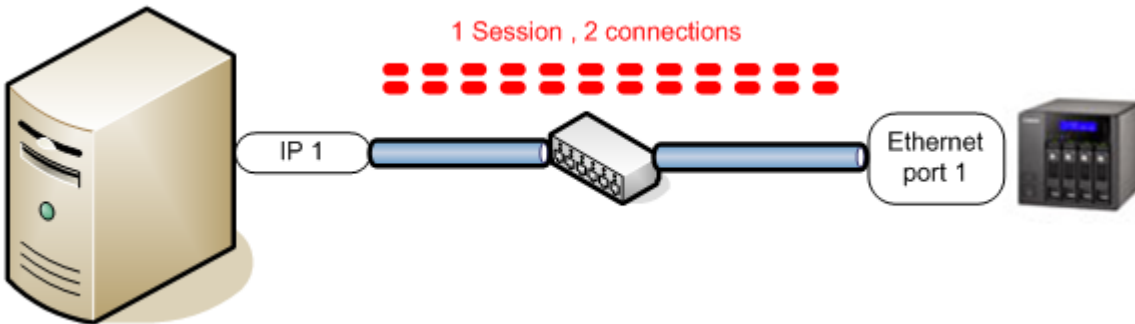

## MC/S over a 2 network interfaces

MC/S can also provide failover. If your server has multiple network interfaces, it is possible to use MC/S in that purpose.

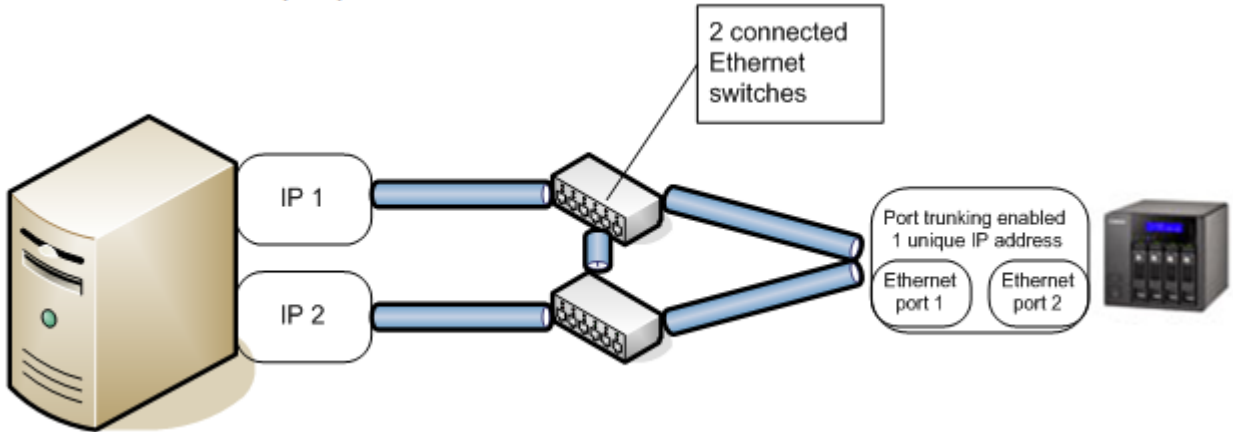

As we've seen previously, after an iSCSI logon, we can add TCP connections to the same session (this procedure will be explained in details later). When adding a TCP connection to a session, it is possible to specify the source interface. In that case, if we connect through the first interface, then add a connection through the second interface. The session will remain alive even if one on the network interface fails.

If your QNAP NAS has 2 network interfaces, you can enable failover mode (trunking mode) to allow failover on both sides.

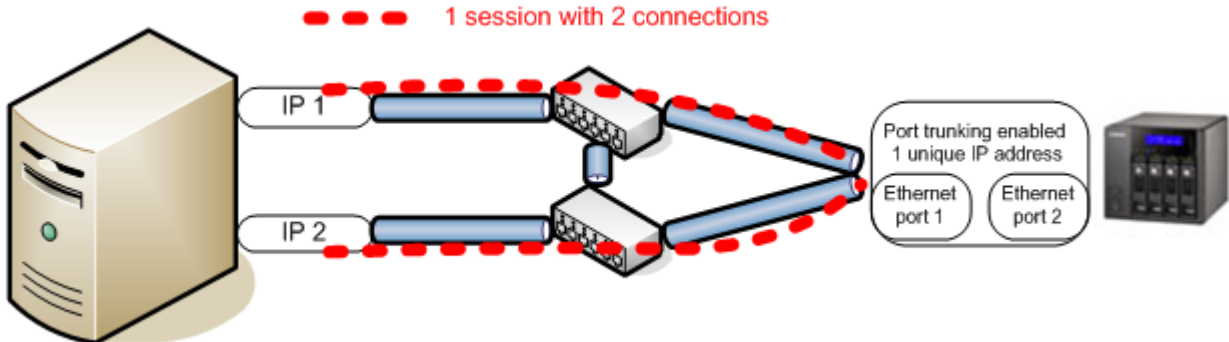

**Different possible failures and failover concept**

---

Handled by MC/S feature

---

If the cable or the switch linked to IP1 or IP2 failed, one of the 2 connections will fail, but the other connection will remain connected:

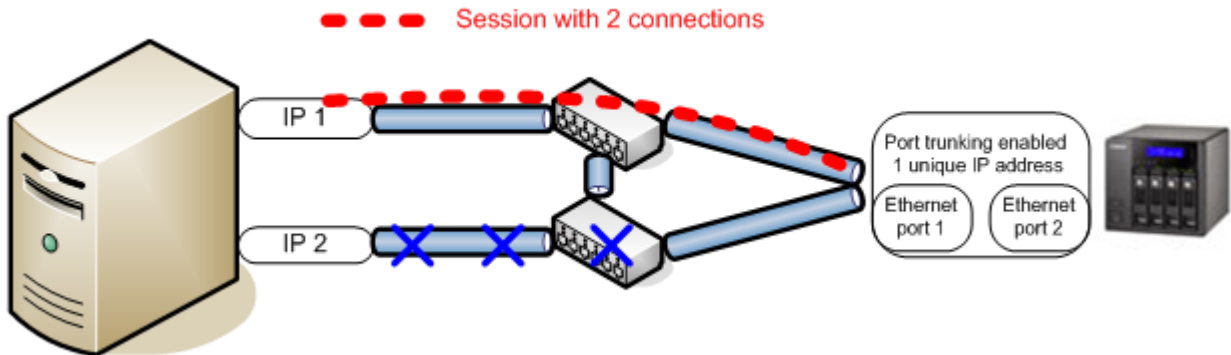
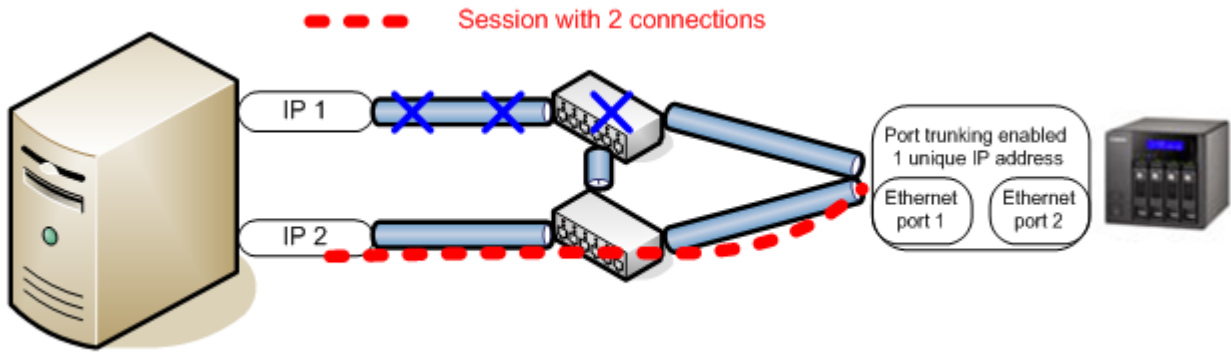

## Handled by QNAP Trunking mode (failover setting)

---

If one of the cable linked to the QNAP NAS failed, the all path will remain UP, because it is protected by the QNAP port trunking mode:

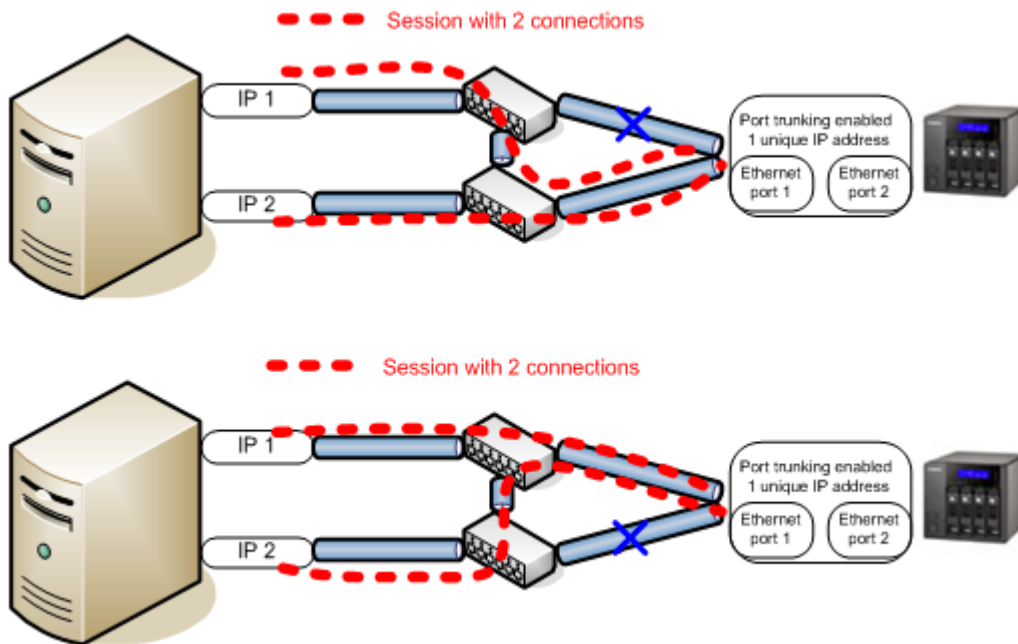

## Pre-requisites of using MC/S (detailed later)

---

- Have an existing iSCSI target created on the NAS (firmware version 3.2.0 or later).
- To allow full network failover, have trunking mode enabled on the QNAP NAS.

## Steps review

---

The following procedure will guide you to:

- Set up an iSCSI target on your QNAP NAS
- Add your QNAP iSCSI portal
- Connect to your iSCSI target
- Add a second connection to your current iSCSI session

## Set up an iSCSI target on your QNAP NAS

---

Set up an iSCSI target on your QNAP NAS. You can refer to the online application note "Create and use the iSCSI target service on the QNAP NAS" on [http://www.QNAP.com/pro\\_features.asp](http://www.QNAP.com/pro_features.asp).

## Connect to your QNAP iSCSI portal

---

You can add an iSCSI LUN.

From the administrative tools, launch the iSCSI Initiator menu:

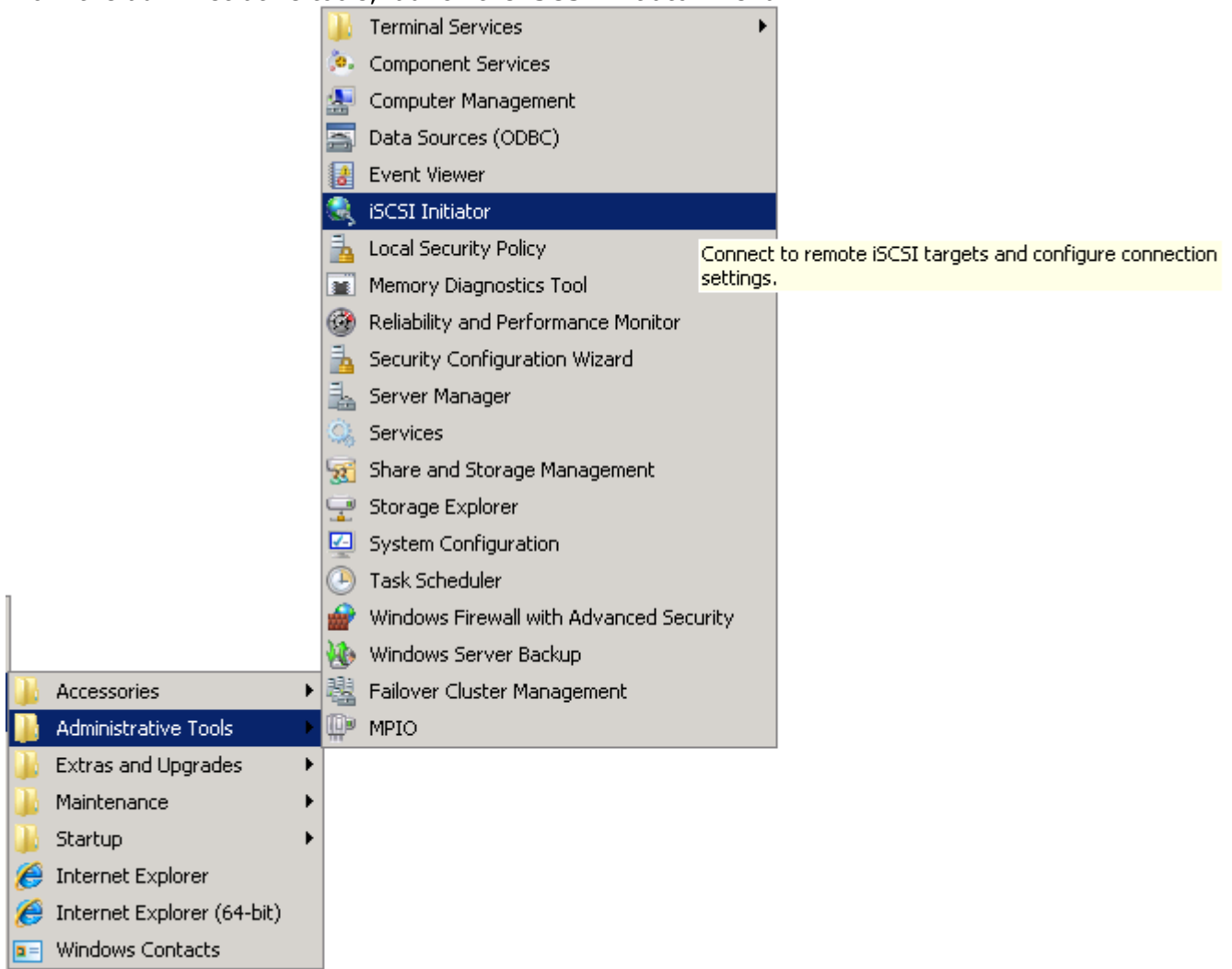

You will obtain a new window. From there you will be able to connect the first path to your iSCSI target.

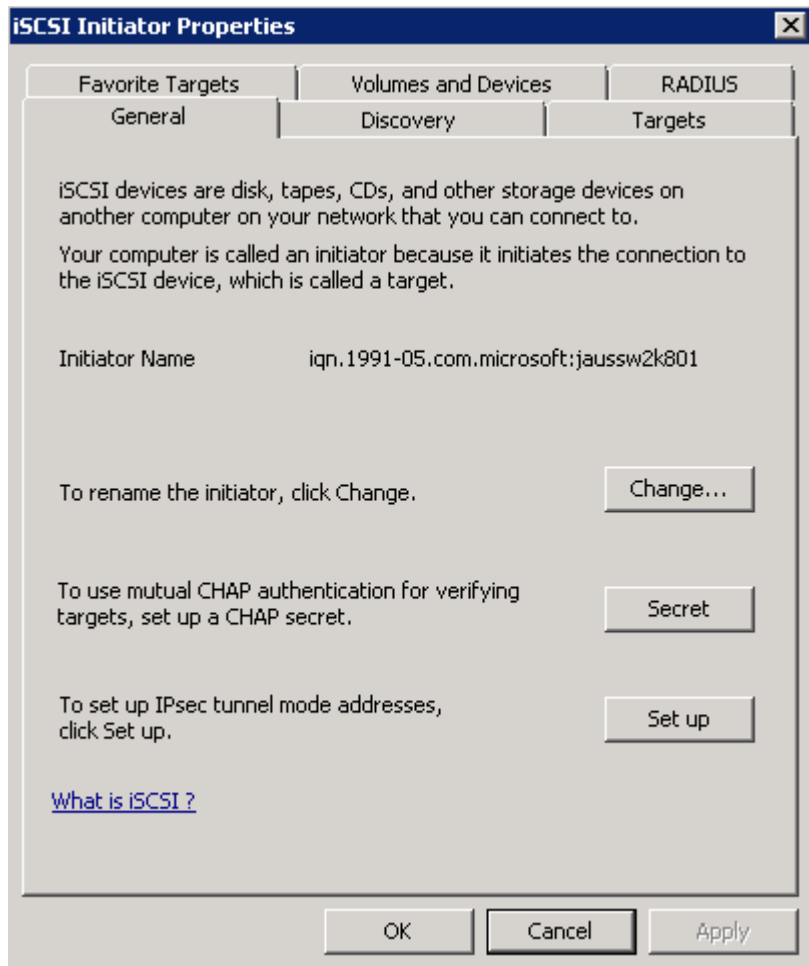

Click the "Discovery" tab, then click "Add Portal" to add your QNAP NAS,

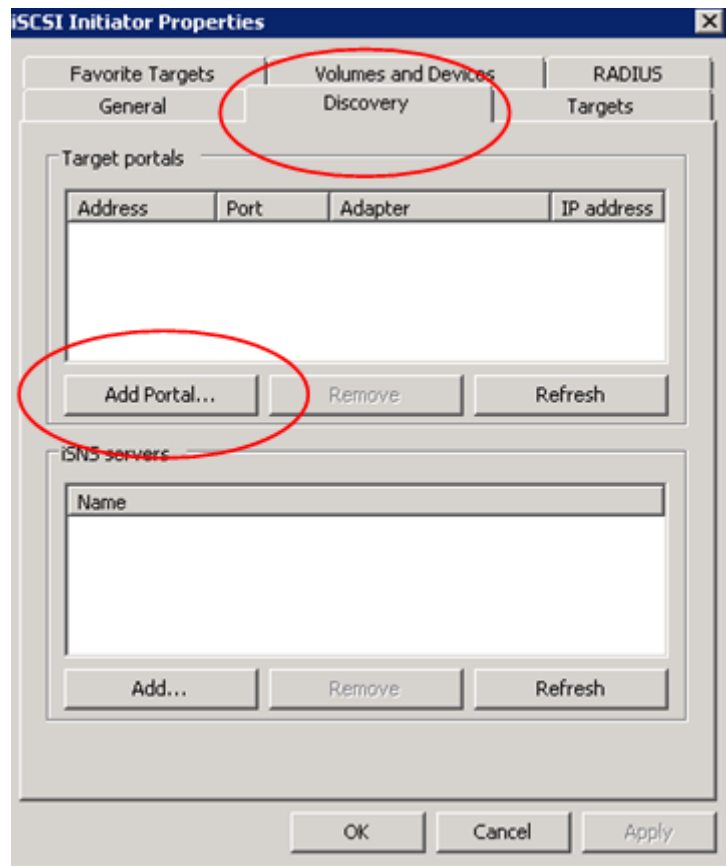

Enter the IP address or DNS name of your QNAP NAS,

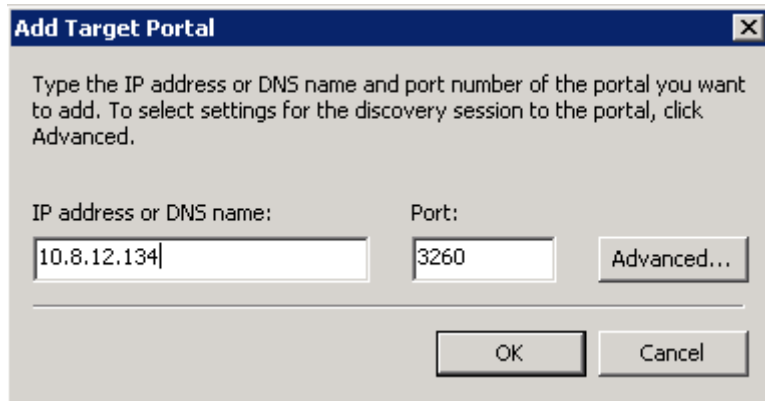

Then click "OK".

Return to the initiator window; go to the "Targets" tab. You will see all the targets on your QNAP NAS.

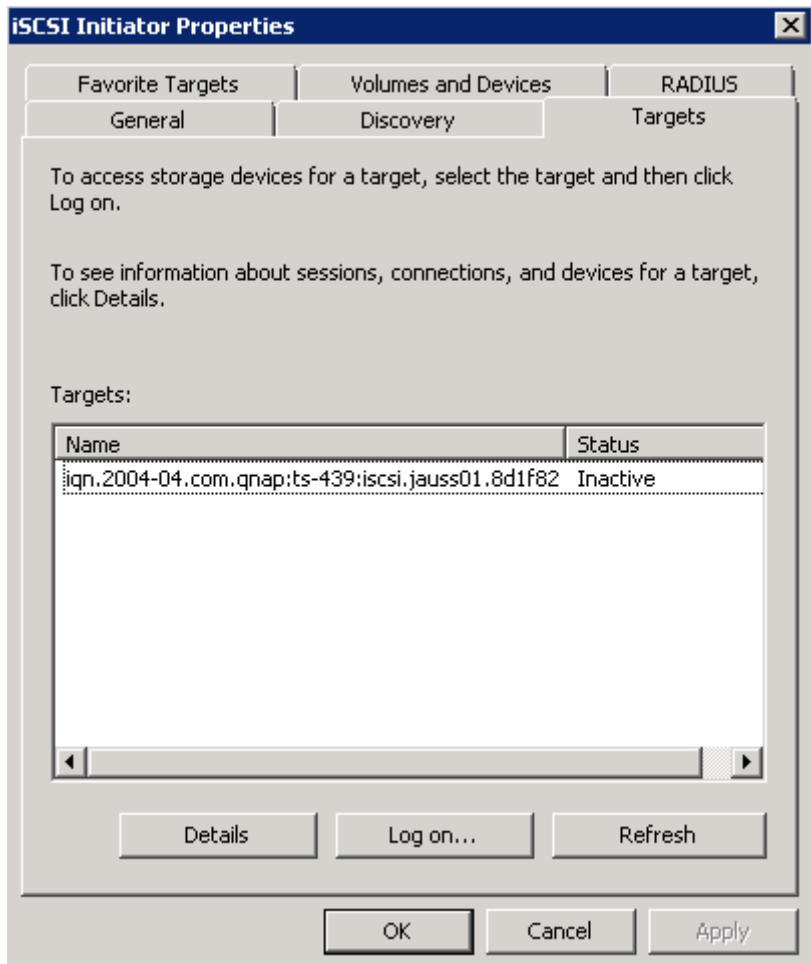

Connect to your iSCSI target (first connection)

Select the target you want to connect to, and click "Log on..."

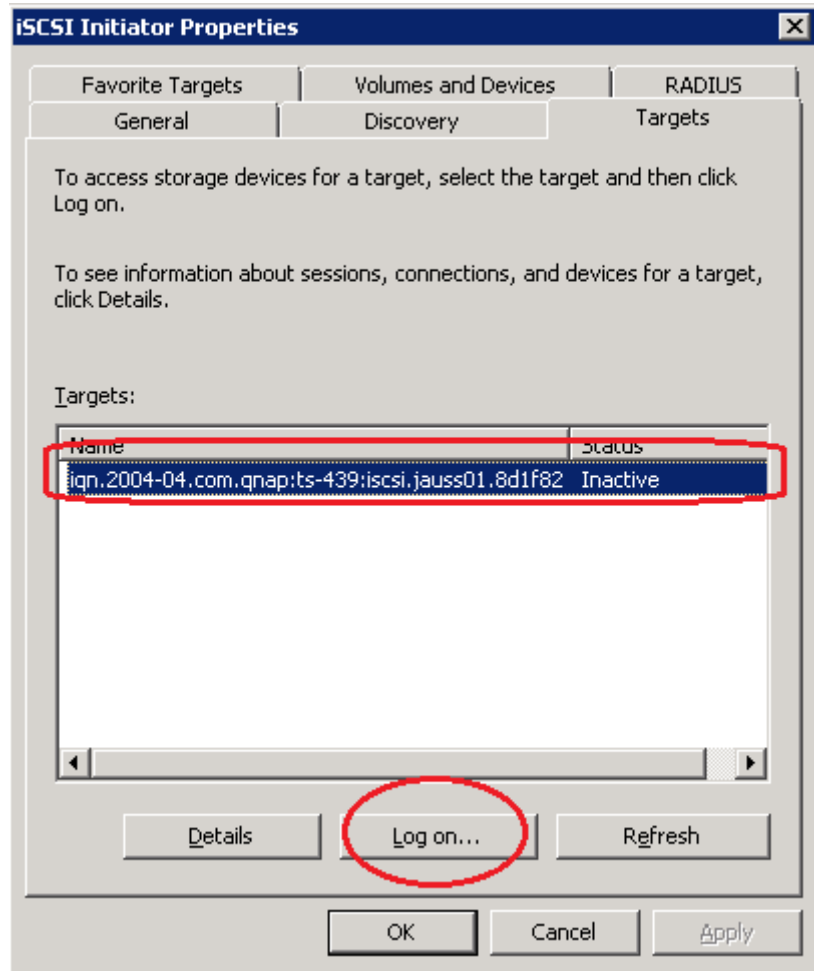

On the new window, check "Automatically restore this connection when computer starts" to make that iSCSI target to be connected at Windows startup.

**DO NOT** check "Enable multi-path".

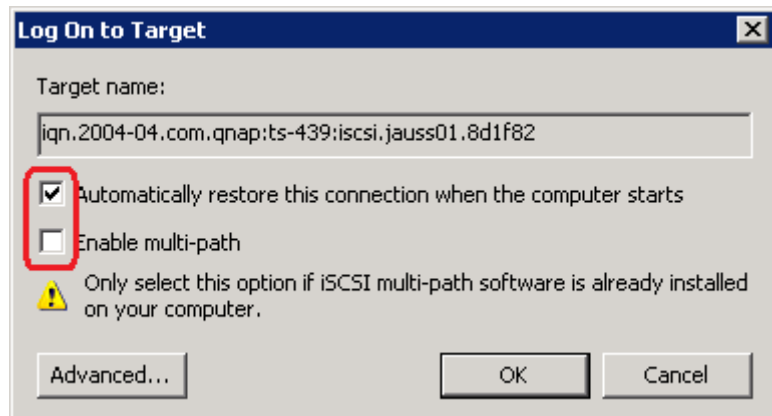

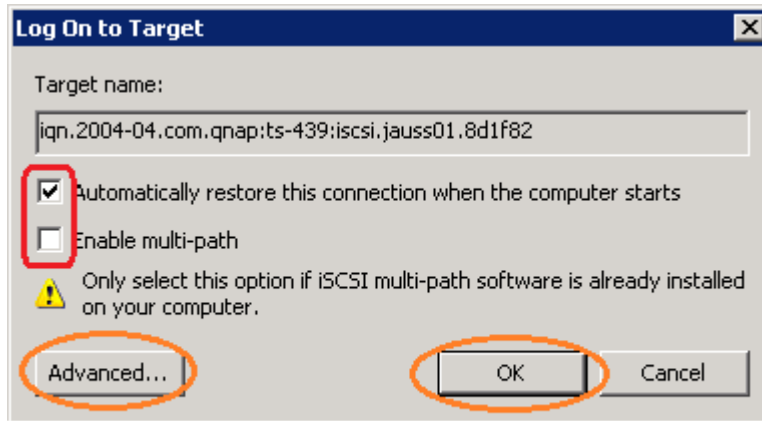

2 Network Interfaces

1 Network Interface

If you have only 1 network interface, just click "OK".

If you have 2 network connections, click "Advanced".

On the "Advanced" tab you can add the specific target-initiator pair in **one of the iSCSI networks ONLY** by choosing the initiator, IP source (first IP) and portal. Assuming we have 2 IP addresses: 172.17.23.210 and 172.17.23.211, we choose the first one: 172.17.23.210:

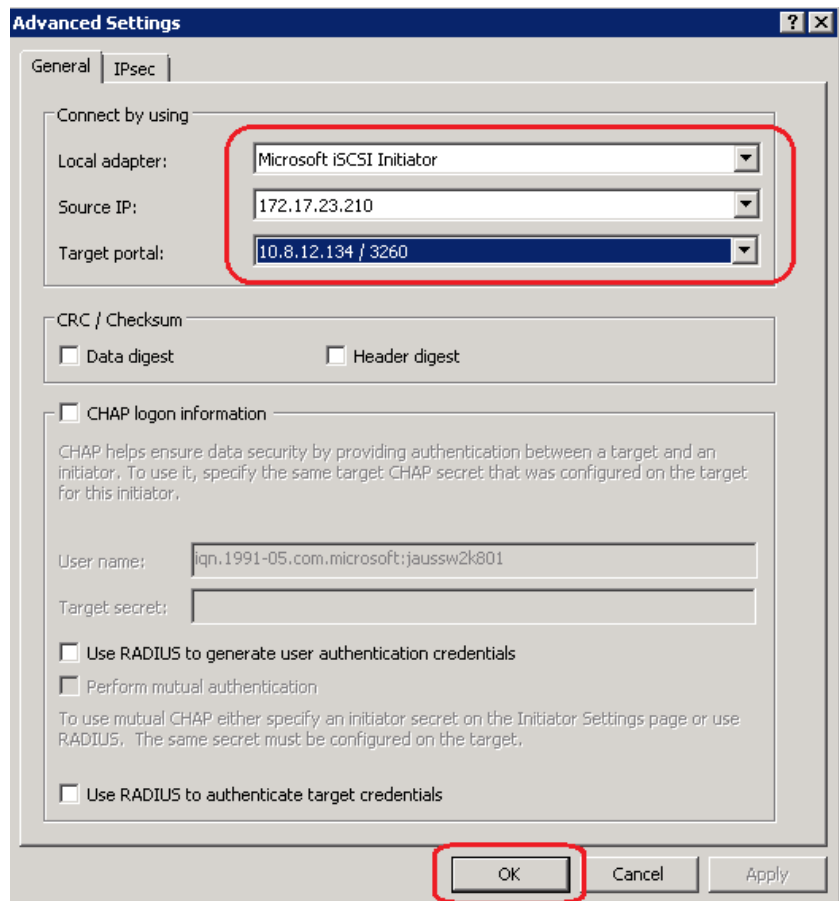

Click "OK"  
Click "OK" again.

Then, you can see your iSCSI target connected.

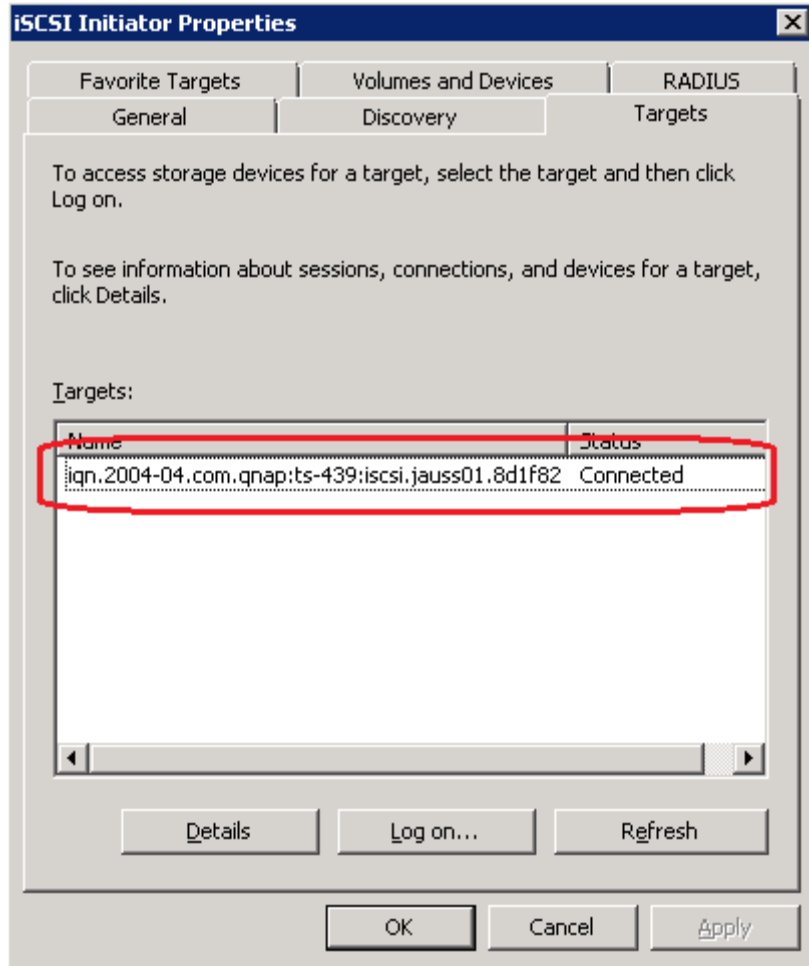

Once you are connected with a first connection, we can add the second TCP connection to the same iSCSI session. To do so, click "Details" after selecting the connected target.

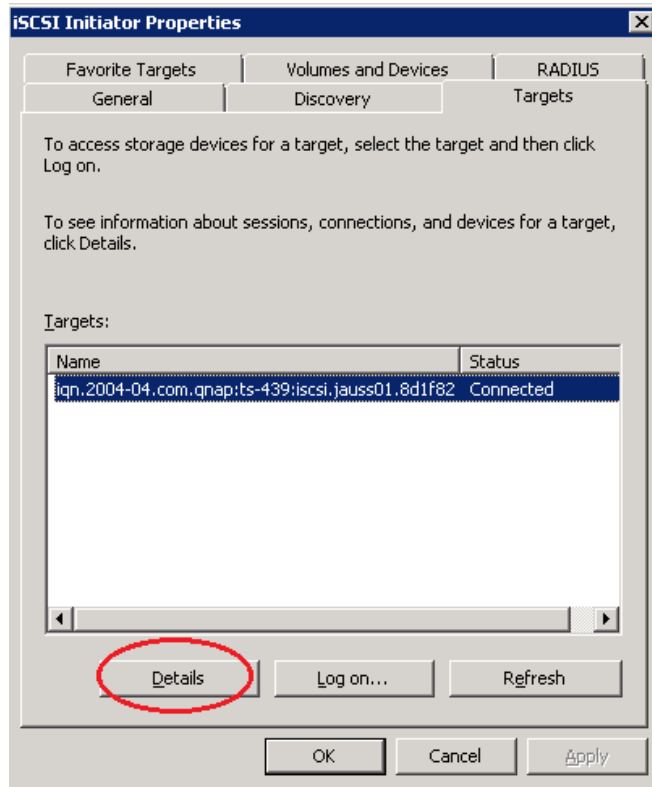

You can see on the next windows the session you have connected before. You can also see that there is only 1 connection "1".

Click "Connections" to add another connection.

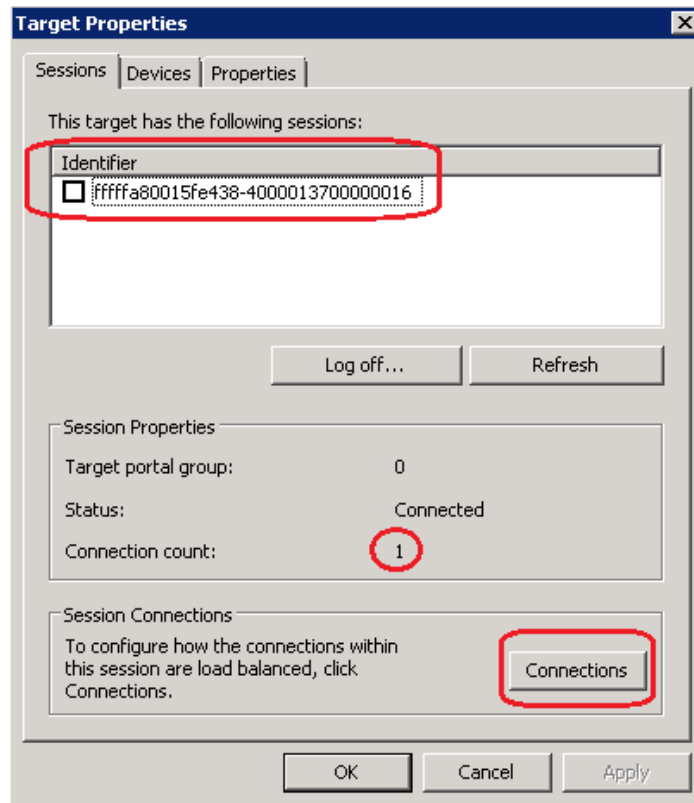

A new window will appear.

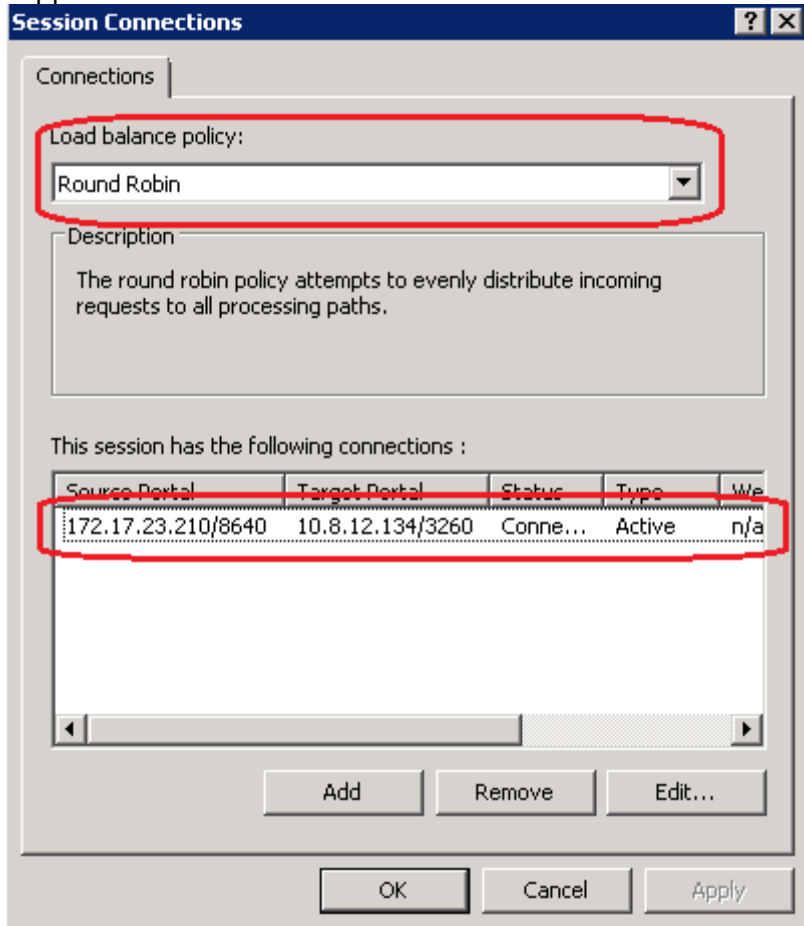

The load balancing policy is shown. The default policy is "Round Robin". You can also see the previous connection that has been done before.

Note that the connection may appear different depending on your configuration:

- With 1 network interface, it may appear without source IP address, because we didn't precise it when we've connected to the target.

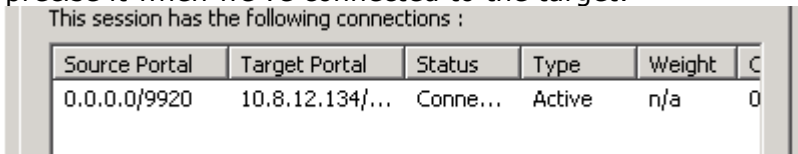

- With 2 network interfaces, we can see the source IP address that we used to connect to the target.

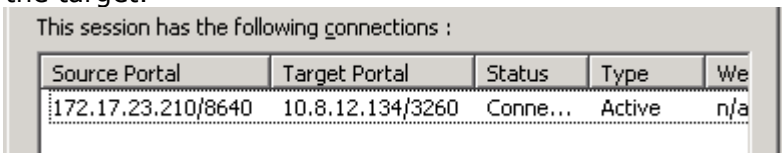

Click "Add" to add a connection.

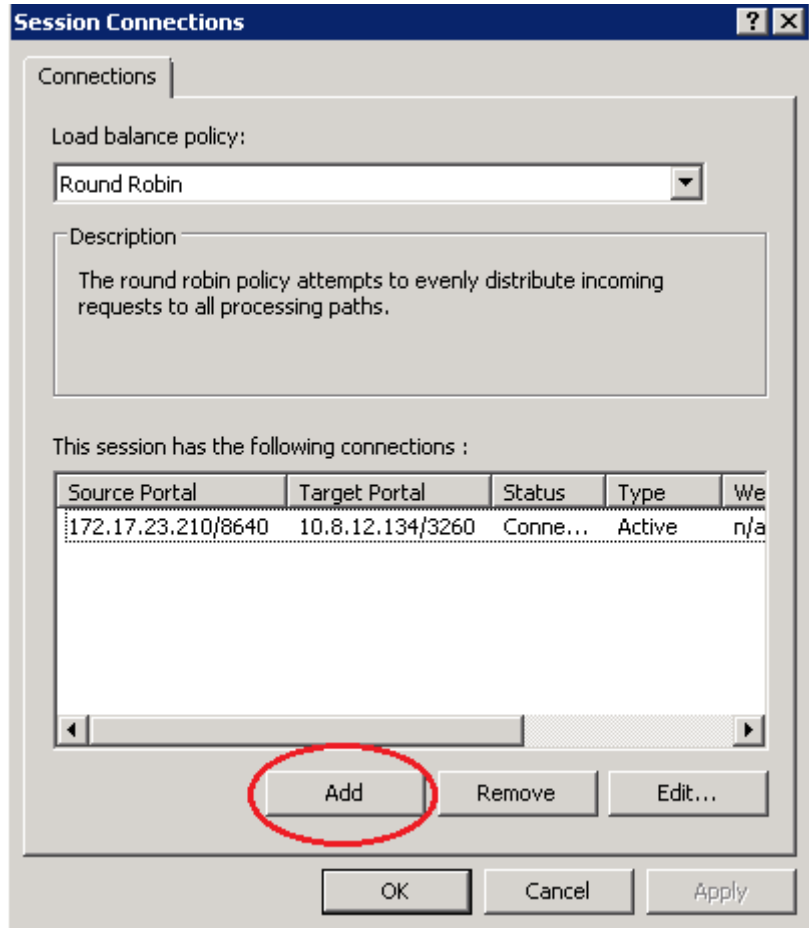

A new window appears.

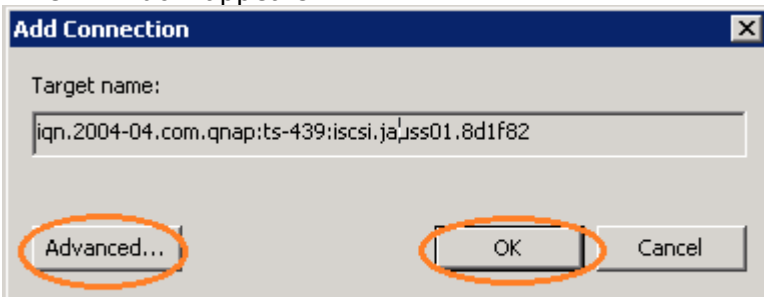

2 Network Interfaces

1 Network Interface

**If you have only 1 network interface**, click "OK".

**If you have 2 network connections**, click "Advanced". Select the initiator, IP source (second IP) and portal for the second connection.

Assuming we have 2 IP addresses: 172.17.23.210 and 172.17.23.211 and that we already connected the first one, we now choose 172.17.23.211 for the second one.

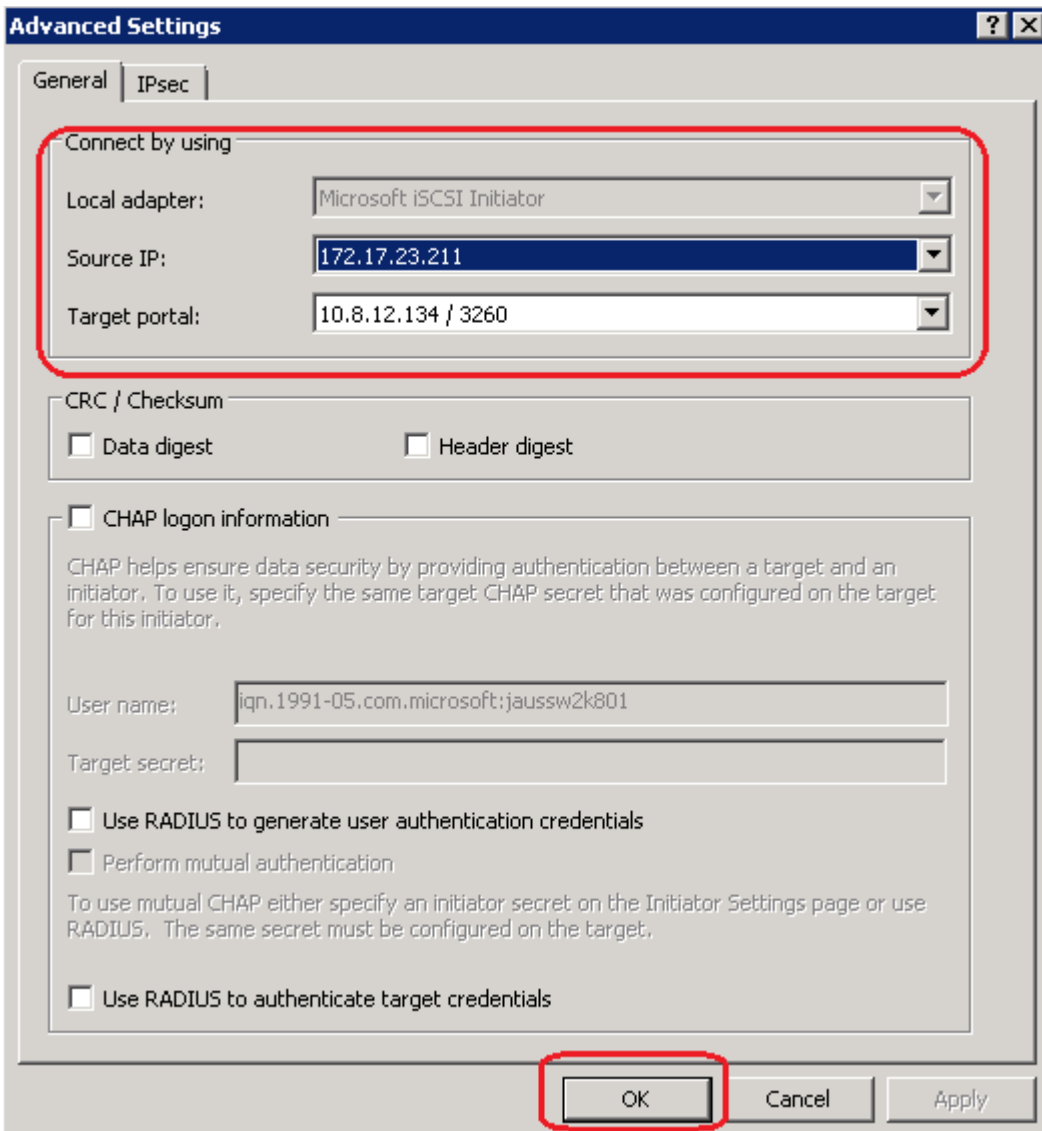

Click "OK". Click "OK" again.

You will see the second connection.

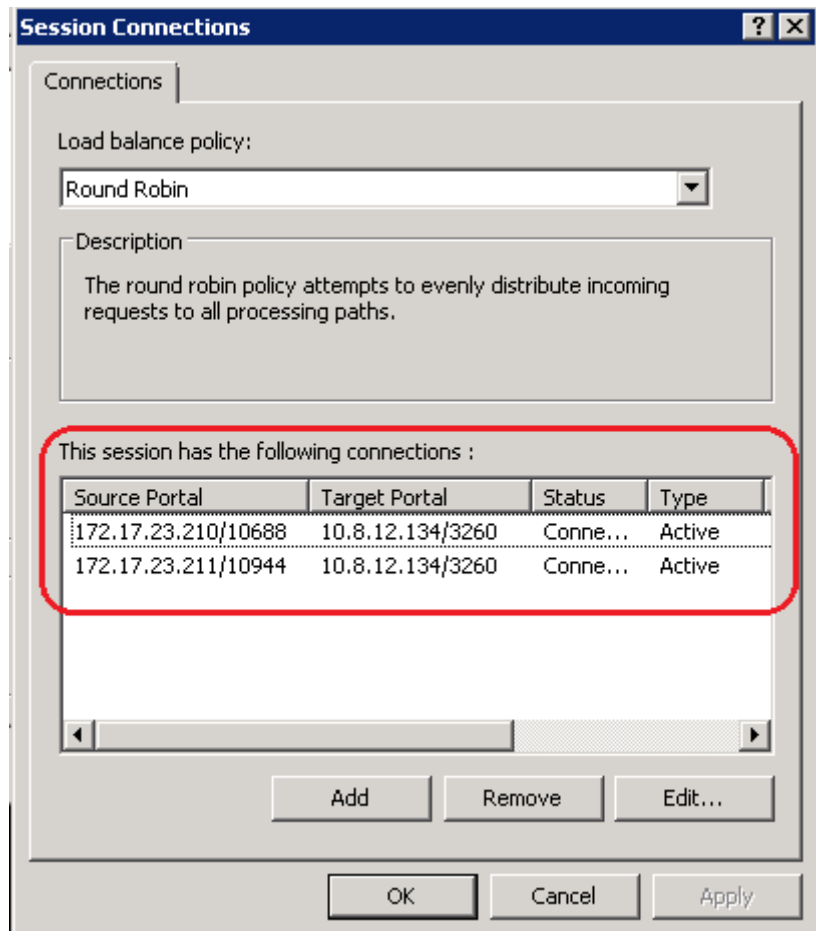

Click "OK".

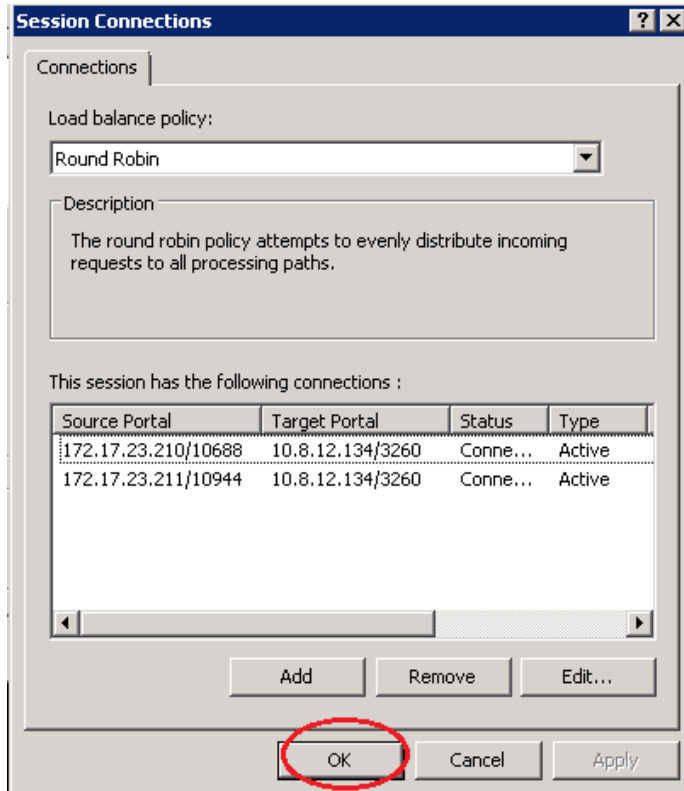

On the new windows, you will find one connected session and two connections.

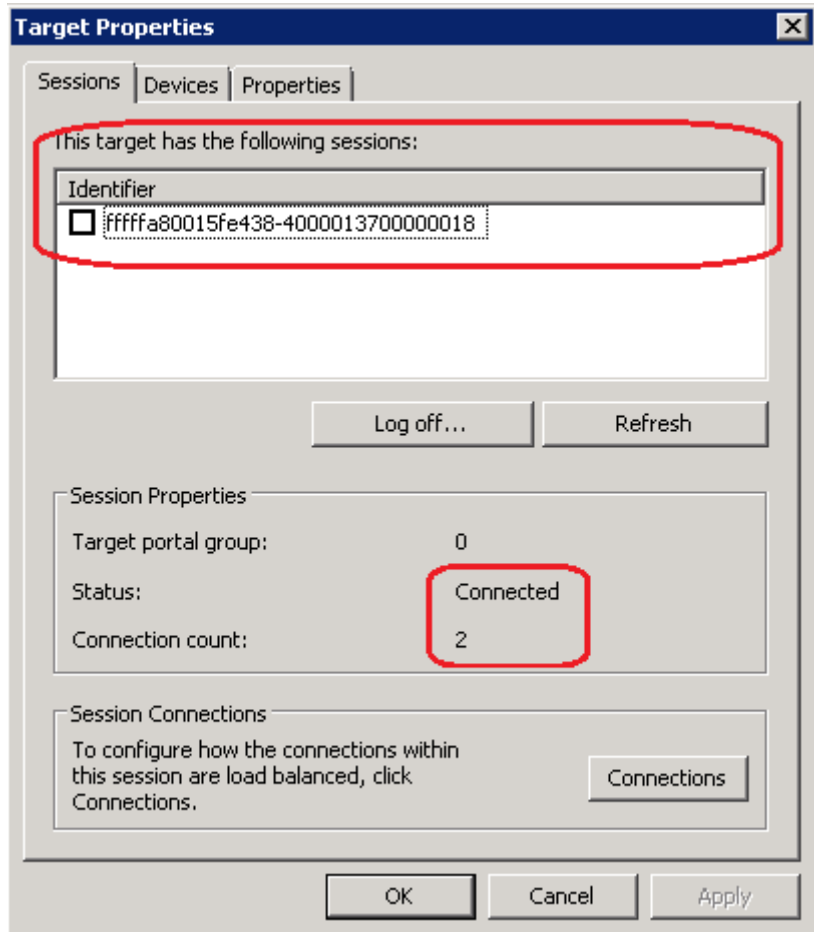

On the "Devices" tab, you will see only 1 disk.

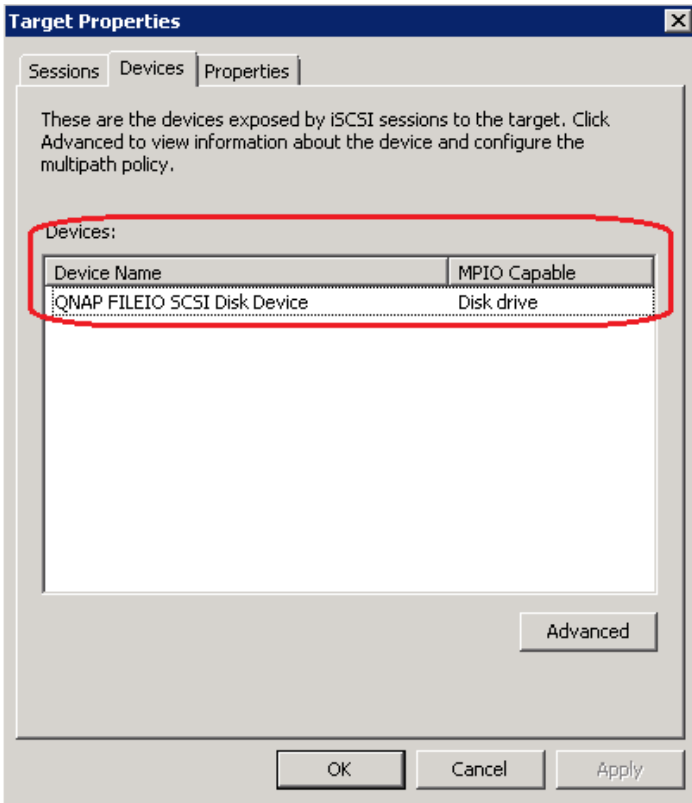

Click "OK".

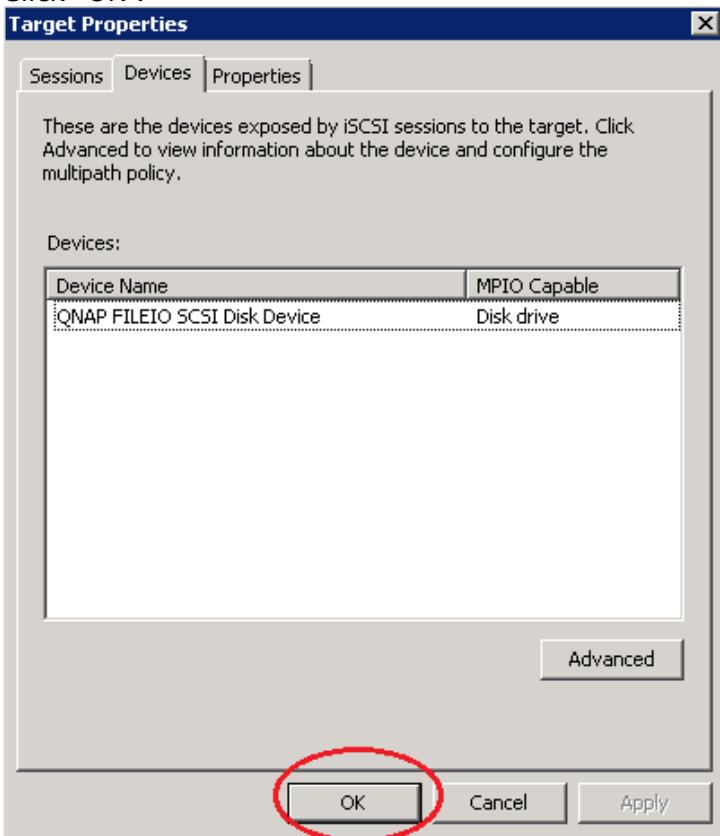

Return to the iSCSI initiator properties, click "OK".

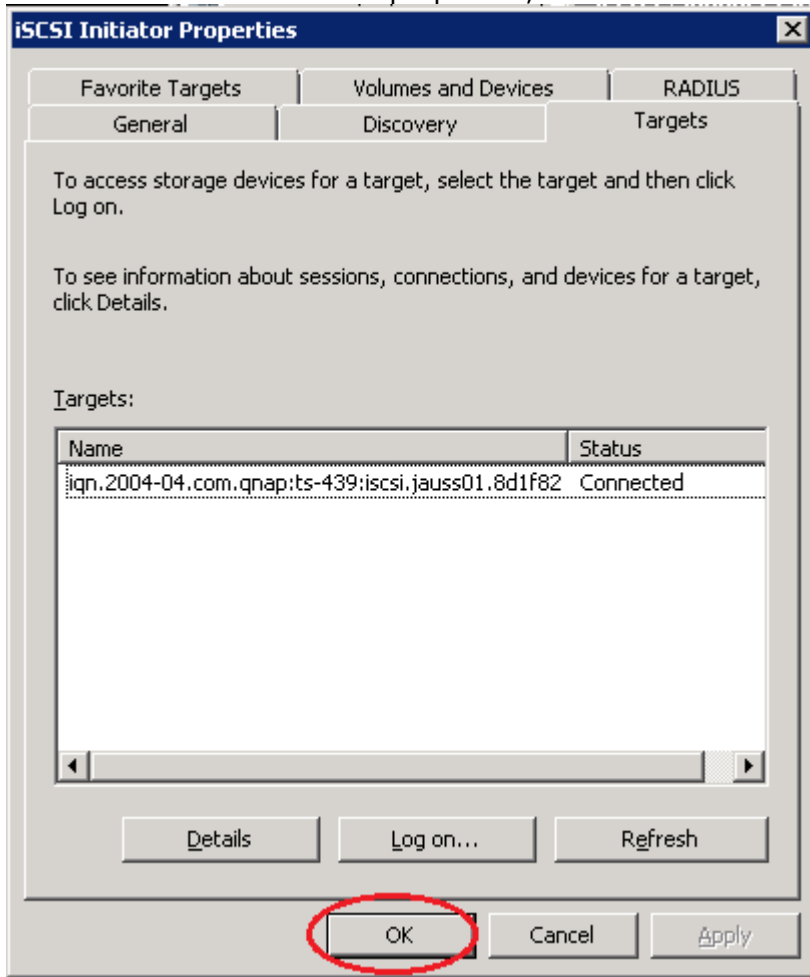

**Check the settings**

- In the main iSCSI initiator panel, select your target LUN and click "Details". You will see your two connected sessions.

On the iSCSI initiator panel, the LUN is connected.



Name	Status
iqn.2004-04.com.qnap:ts-439:iscsi.jauss01.8d1f82	Connected

Click "Details".

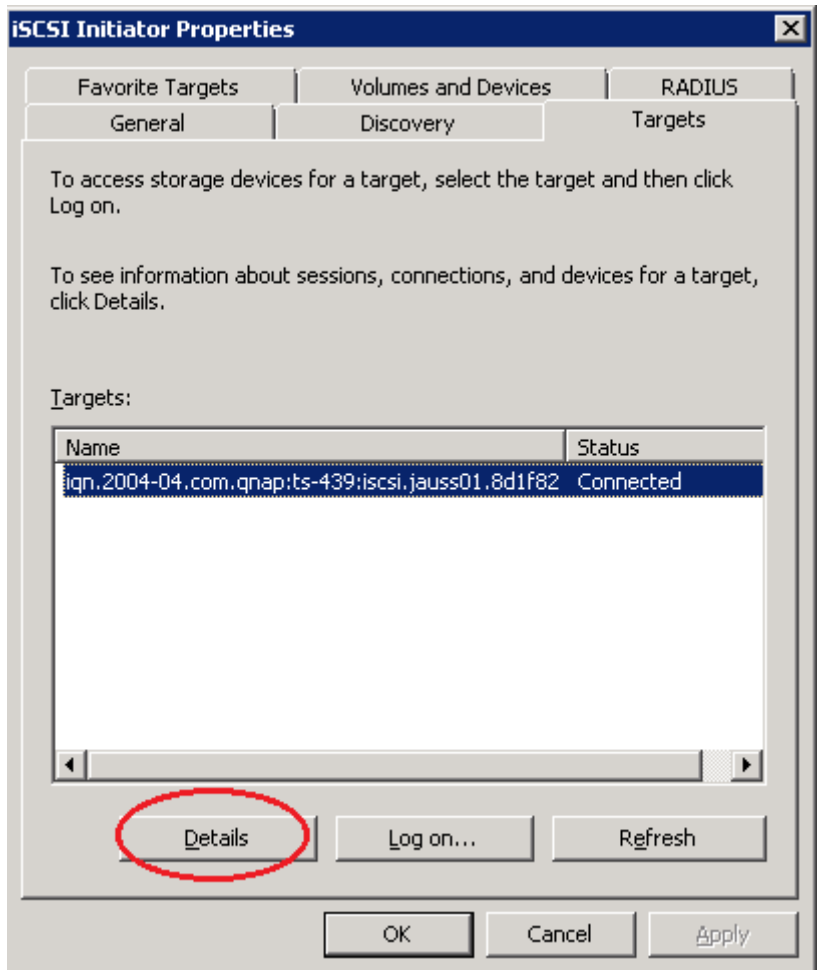

**iSCSI Initiator Properties**

Favorite Targets | Volumes and Devices | RADIUS

General | Discovery | Targets

To access storage devices for a target, select the target and then click Log on.

To see information about sessions, connections, and devices for a target, click Details.

Targets:

Name	Status
iqn.2004-04.com.qnap:ts-439:iscsi.jauss01.8d1f82	Connected

Details | Log on... | Refresh

OK | Cancel | Apply

You can see the 1 session with 2 connections.

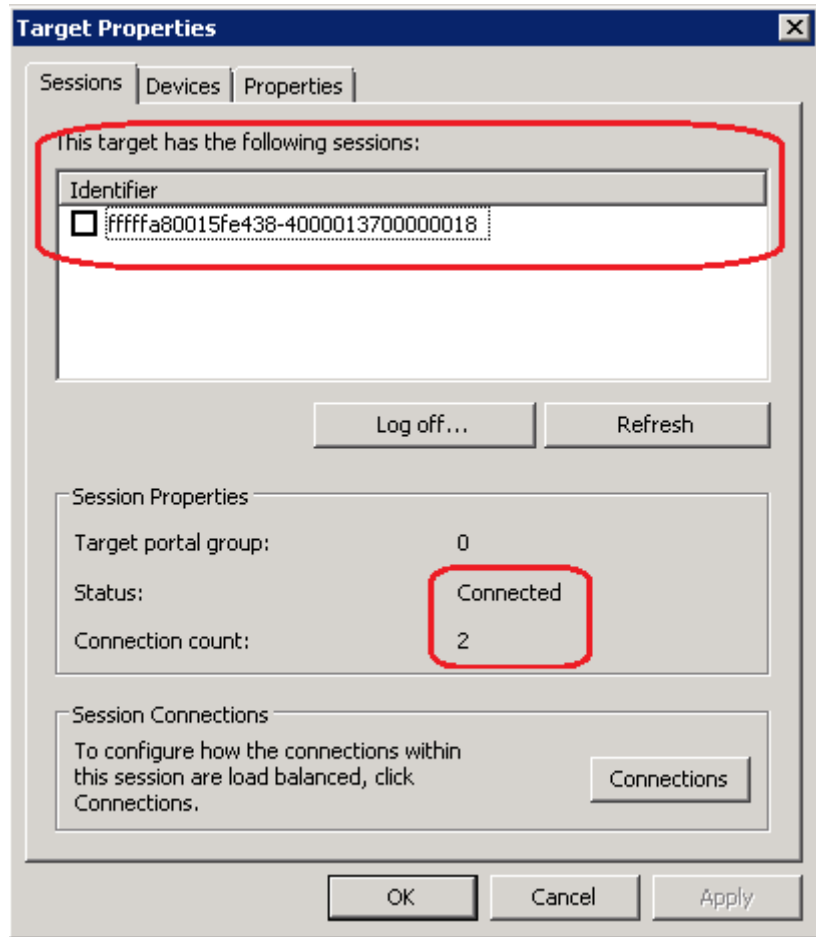

**If you have only 1 network interface:**

You can also find those 2 connections by opening a command prompt window (cmd.exe) and using netstat.exe. We can see the 2 connections that you made from the same IP address:

```
C:\Users\Administrator>netstat -n

Active Connections

Proto Local Address          Foreign Address         State
TCP   172.17.23.210:49173    10.8.12.134:3260      ESTABLISHED
TCP   172.17.23.210:49174    10.8.12.134:3260      ESTABLISHED
TCP   172.17.23.214:3389    10.8.12.35:53523     ESTABLISHED

C:\Users\Administrator>
```

**If you have 2 network connections,**

you can also find those 2 connections by opening a command prompt window (cmd.exe) and using netstat.exe. We can see the 2 connections that you made from the 2 different IP addresses.

```
C:\Users\Administrator>netstat -n

Active Connections

Proto Local Address          Foreign Address         State
TCP   172.17.23.210:49164    10.8.12.98:3260      ESTABLISHED
TCP   172.17.23.211:49165    10.8.12.98:3260      ESTABLISHED
TCP   172.17.23.214:3389    10.8.12.35:56117     ESTABLISHED

C:\Users\Administrator>
```

- In Server Manager console, go to "Storage" > "Disk Management". You can configure the newly added disks as appropriate.

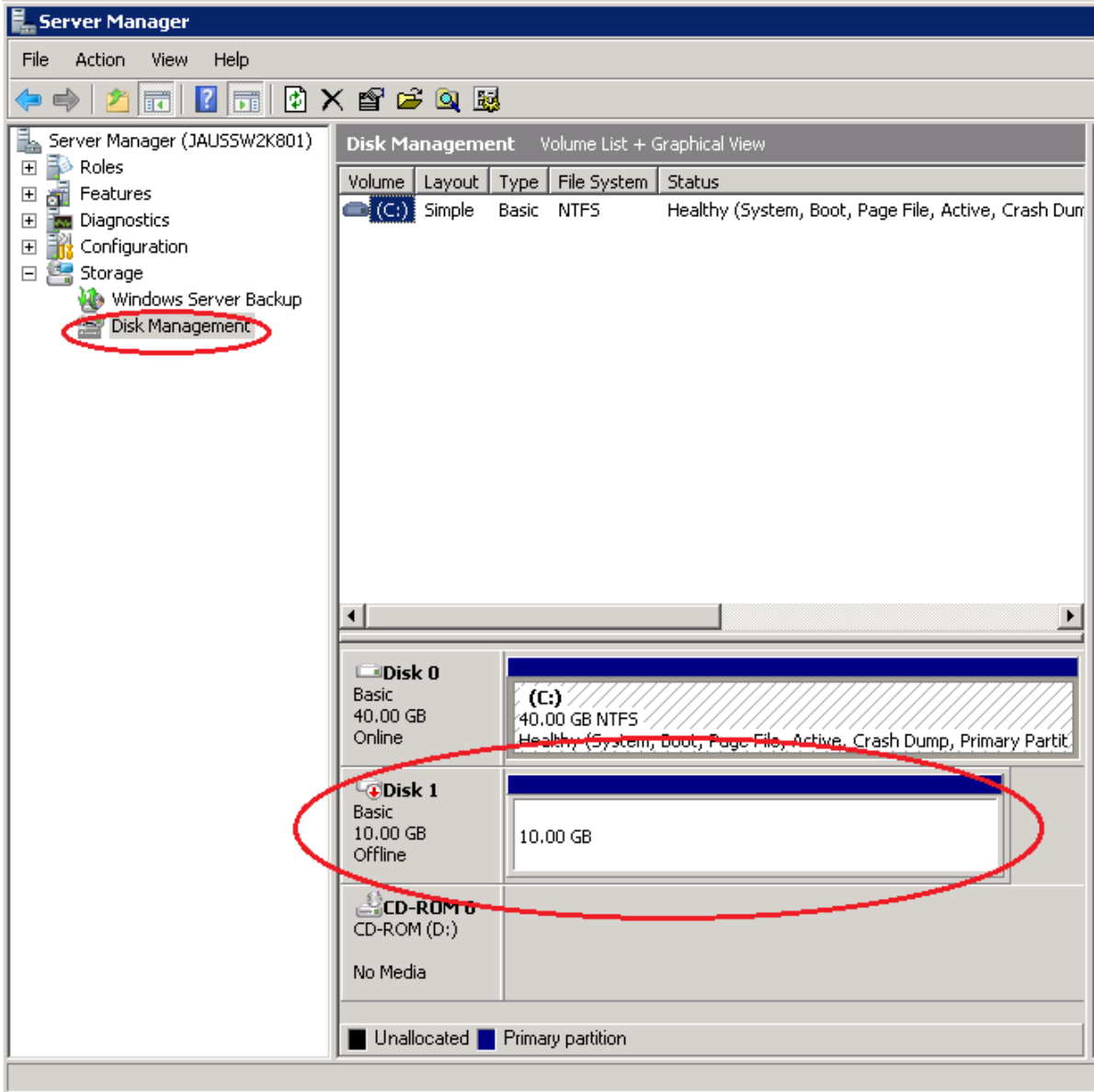

You can format your newly added disk and use it:

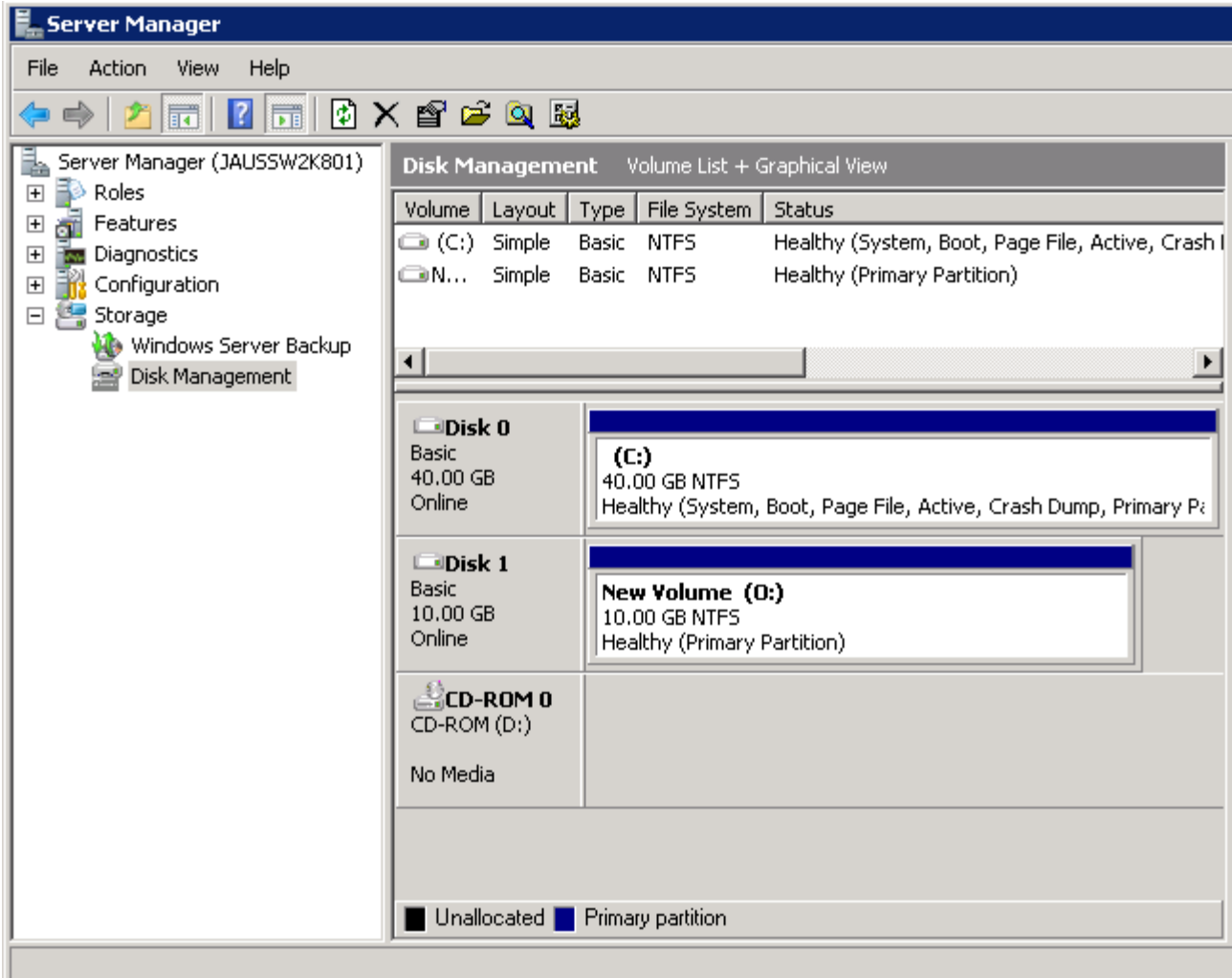

## Example of a failover

During the formatting of the disk, one of the network cables has been disconnected, the system started to use only the remaining connection (1).  
When the cable is plugged back, the first connection is reestablished (2).

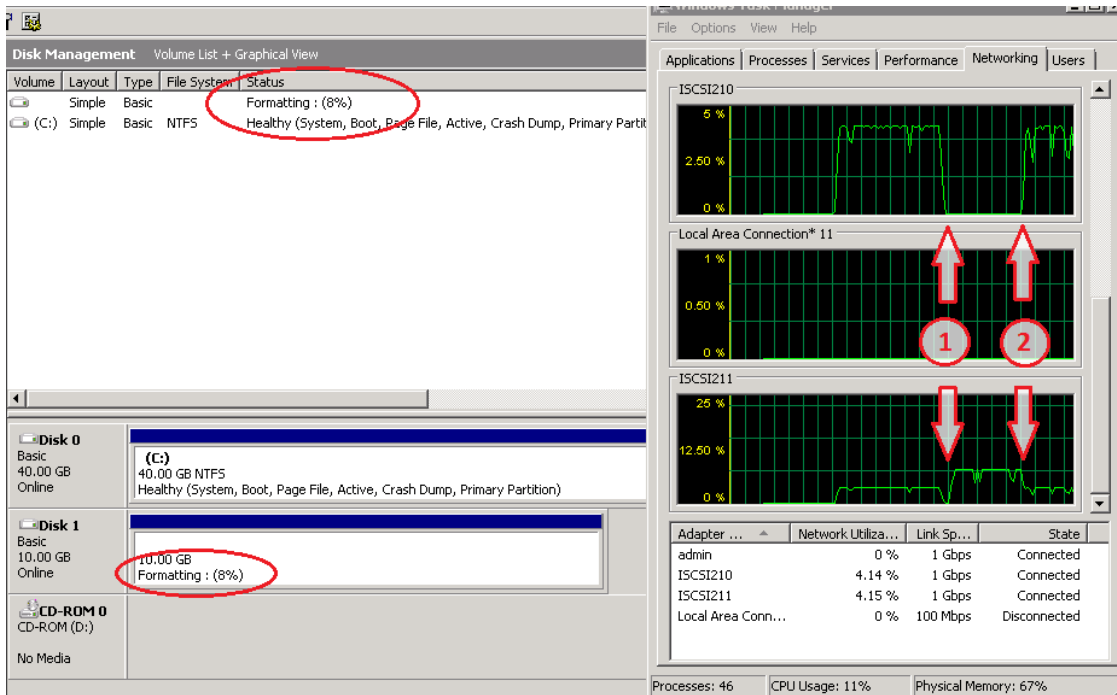

**Advices**

---

According to *Microsoft iSCSI Software Initiator Version 2.X Users Guide*, you can enable Jumbo Frame (Jumbo packet) on all your equipment to enhance performance.

*"if Jumbo Frames if supported in your network infrastructure. Jumbo Frames can be used to allow more data to be transferred with each Ethernet transaction and reduce the number of frames. This larger frame size reduces the overhead on both your servers and iSCSI targets. For end to end support, each device in the network needs to support Jumbo frames including the NIC and Ethernet switches."*

(Beware that Jumbo Frame are available on TS-119, TS-219, TS-219P, TS-410, TS-419P, TS-419U, TS-239 Pro, SS-439 Pro, TS-439 Pro, TS-439U-SP/RP, TS-639 Pro, SS-839 Pro. Cf: [http://www.QNAP.com/images/products/comparison/Comparison\\_NAS.html](http://www.QNAP.com/images/products/comparison/Comparison_NAS.html) )

On your Windows 2008 server, configure your network interface properties.

---

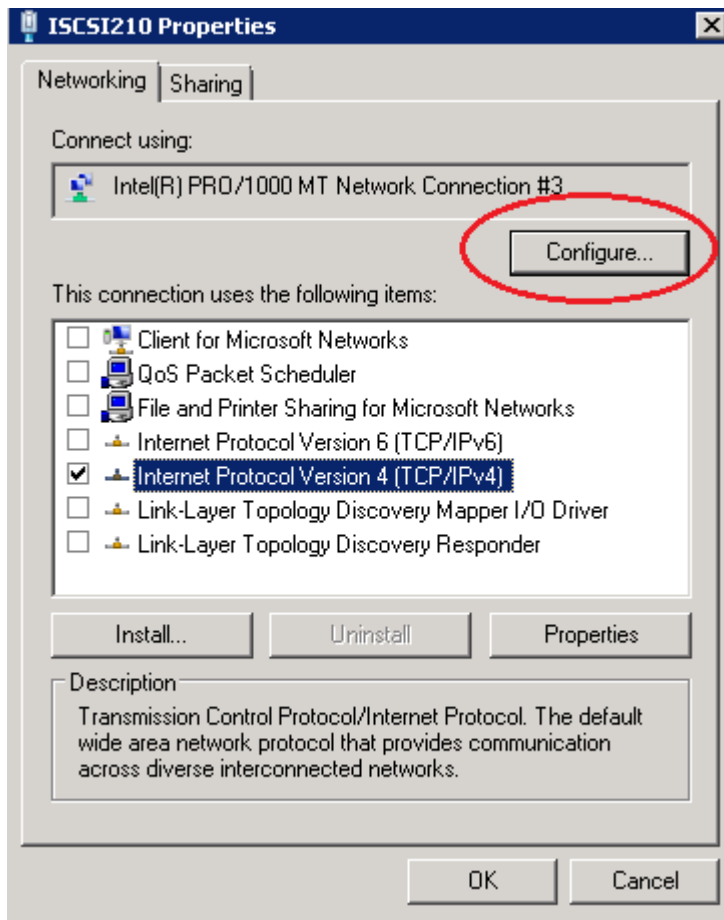

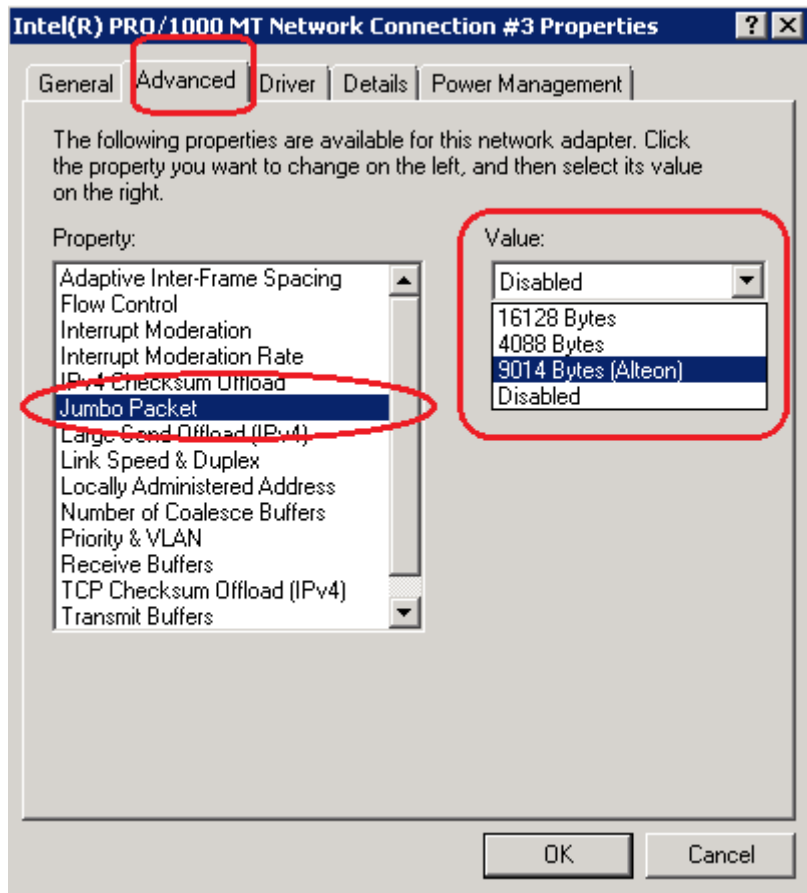

On your NAS administration interface

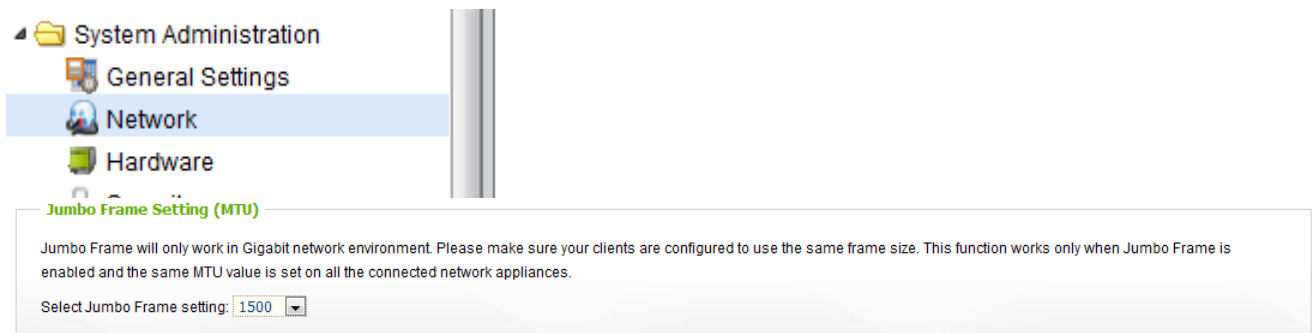

## You can also unbind unnecessary protocols from your iSCSI NICs

This has to be done only on DEDICATED network interfaces that are used only for iSCSI!

- Clear the checkbox for "Client for Microsoft Networks"
- Clear the checkbox for "QoS Packet Scheduler"
- Clear the checkbox for "File and Printer Sharing for Microsoft Networks"
- Clear the checkboxes for the "Link-Layer Topology" options
- Clear the checkbox for "Register this connection's address in DNS"
- Clear the checkbox for "Enable LMHOSTS Lookup"
- Select the radio button for "Disable NetBIOS over TCP/IP"

